



WAMA ELECTRONICS TECH CO.,LTD

1.[SCOPE]

This specification applies to the following 3.0v lithium button cell CR2016 made by WAMA ELECTRONICS TECH CO.,LTD.

2.[RATINGS]

TABLE I:

ITEM		UNIT	SPECIFICATIONS	CONDITIONS
Nominal voltage		V	3.0	Standard discharge
Nominal capacity		mAh	80	Standard discharge
Instantaneous short-circuit current		mA	≥300	Time≤0.5second
Off-load voltage		V	≥3.20	Unit cell
Storage temperature			0-35	
Standard weight		g	1.8	Unit cell
Service output	Initial	h	75	Continuous discharge with load 3 kΩ,till 2.0v end-voltage at 20-25
	After 12 months storage	h	73.5	

TABLE II:

ITEM	CONDITIONS	CHARACTERISTICS
Self-discharge rate	Stored for 12 months at normal temperature,then continuously discharged with 30 kΩ load till 2.0v end-voltage	Less than ≤2%

3.[PERFORMANCE AND TEST METHODS]

Unless otherwise stated,all the testing is carried out under the condition:

environmental temperature: 20 -25 ;

environmental humidity: 65±20%.



4.[SUGGESTIONS AND CAUTIONS]

- 4.1 Install batteries correctly
- 4.2 Ensure the contact points to be clean and conductive
- 4.3 Do not mix different types,different brands batteries to serve together
- 4.4 Do not heat,recharge the batteries
- 4.5 Do not dispose of the batteries in fire
- 4.6 Keep away form the small children,if swallow promptly see doctor
- 4.7 Pay attention to the producing date

TABLE III:

NO	ITEM	TEST METHODS	STANDARD	
1	Dimensions	Using vernier caliper(accuracy ≥ 0.02) while avoiding short-circuit	Diameter	20.0(± 0.2)mm
			Height	1.60(± 0.2)mm
2	Off-load voltage	Using multimeter(accuracy $\geq 0.25\%$)internal resistance $\geq 1M\Omega$	$\geq 3.20V$	
3	Instantaneous Short-circuit current	Time of short-circuit should be less than 0.5 Sencond and avoid repeated test within half An hour	$\geq 300mA$	
4	Appearance	Eyeballing	Bright ,clen,no rust, no leakage, And no flaw	
5	Capacity	Continuously discharge for 8 hour with load 3k Ω ,temperature at 20-25 ,humidity at 65 $\pm 20\%$ till 2.0v end-voltage(for fresh battery only:within 3 months)	$\geq 75h$	
6	Vibration test	Put battery on the platform of the vibrations Machine,start the machine and adjust the Frequency form 10 times per minute to 15 Times per minute.keep it running for an hour	Characteristics keep stability	
7	Leakage at high temperature	Stored under temperature (45) for 30 days	Leakage rate $\leq 0.5\%$	
8	Over Discharge Test	After 2.0v end-voltage, continuously discharged for 5 hours	No leakage allowed	



5.[DISCHARGE CHARACTERISTICS]

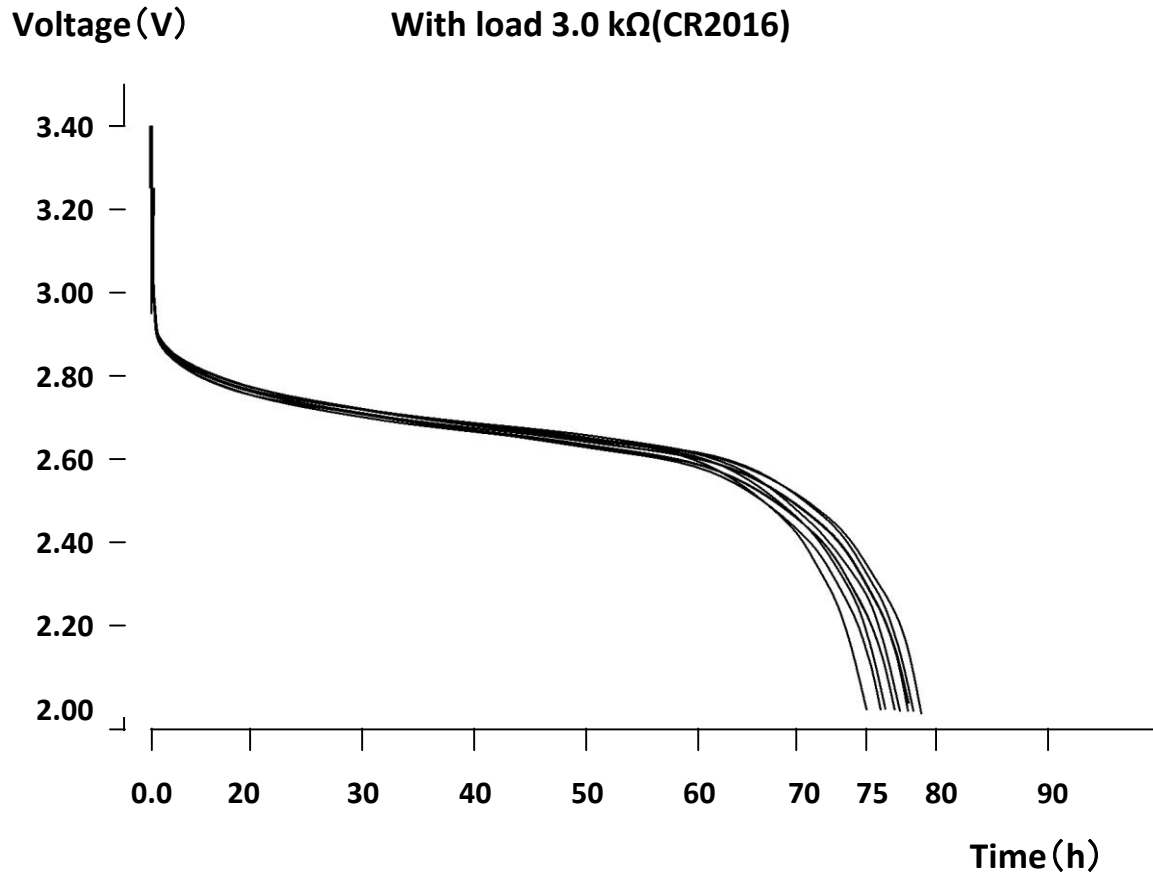

6.[Dimension:mm]

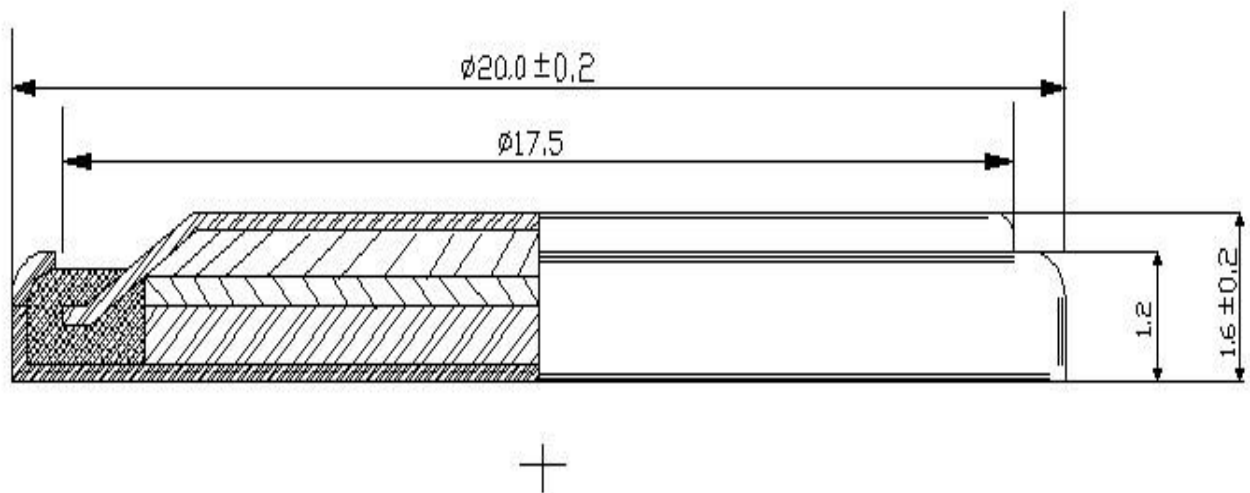

Discharge Characteristics / 放电特性

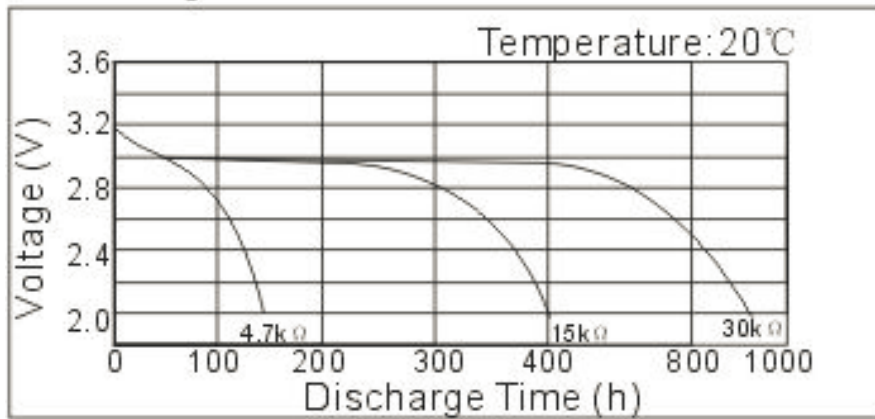

Temperature Characteristics / 温度特性

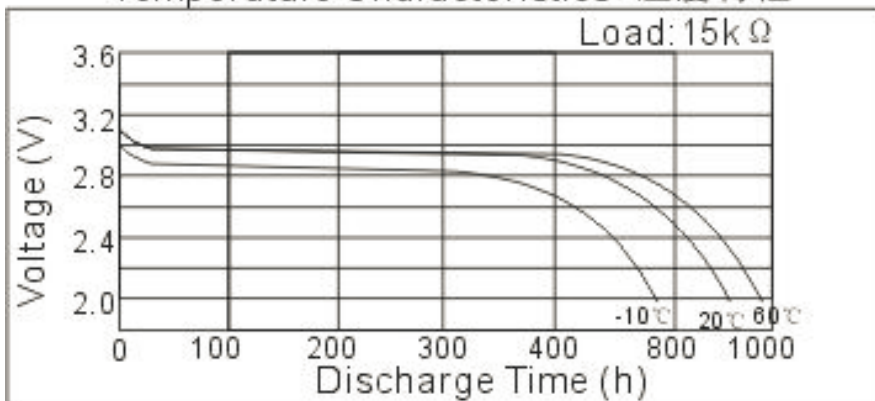

Load-Capacity / 负载容量

