

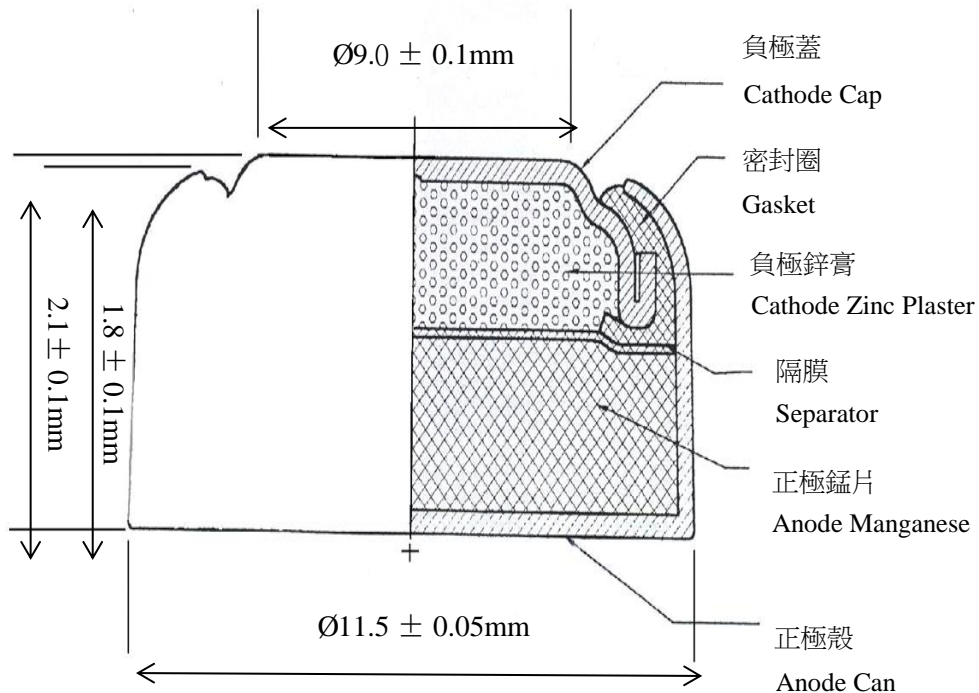

# WAMA ELECTRONICS TECHNOLOGY CO.,LTD

## AG8,LR1120,391/381 BUTTON CELL

### DIMENSIONS:



**NOMINAL VOLTAGE : 1.5 VOLT**

**APPROX. SERVICE CAPACITY : 45 mAh**

**APPROX. WEIGHT : 0.86 g**

**RATED AT 7.5KΩ LOAD TESTED AT 21°C WITHIN 30 DAYS OF MANUFACTURE.**

**SYSTEM : ZINC /MANGANESE DIOXIDE.**

### ESTIMATED AVERAGE HOURS SERVICE AT 21 °C

